

Reconfiguration of a Distributed Information Fusion System

Éric Benoit, Marc-Philippe Huget, Patrice Moreaux, Olivier Passalacqua*

* LISTIC, Polytech'Savoie, Université de Savoie, 74944 Annecy le Vieux, France (e-mail: firstname.lastname@univ-savoie.fr).

Abstract: Information Fusion Systems are now widely used in different fusion contexts, like scientific processing, sensor networks, video and image processing. One of the current trends in this area is to cope with distributed systems. In this context, we have defined and implemented a Dynamic Distributed Information Fusion System runtime model. It allows us to cope with dynamic execution supports while trying to maintain the functionalities of a given Dynamic Distributed Information Fusion System. The paper presents our system, the reconfiguration problems we are faced with and our solutions.

Keywords: Availability, Data fusion, Decision making, Discrete-event dynamic systems, Performance evaluation, Run-time systems,

1. INTRODUCTION

The aim of an Information Fusion System is to compute *results of higher quality* (with respect to some criteria to be defined) from information provided to it either from the "real world" (sensor networks) or from computer sources (databases for instance). Present IFS are frequently *distributed* since data sources or/and computation resources power are actually distributed.

Computer based Information Fusion Systems are widely diffused since a couple of decades (see for instance [Maître and Bloch (1997); Kam et al. (1997)]). Although there are already a lot of solutions to develop and to deploy Distributed Information Fusion Systems (DIFS), see [Horré et al. (2007)] for a survey of solutions in the sensor network area for instance, most of them are restricted to specific application areas. Moreover, they frequently assume that the execution support system is fixed.

The goal of our project is to define a runtime framework for Dynamic Distributed Information Fusion System (DDIFS). This framework is based on a model of the Fusion Process (FP) and on a model of its derived runtime deployment. These two models allow us to control the DDIFS:

- the system restores a correct state after a run-time error;
- the system modifies itself when it detects that a better configuration, in a sense to be detailed, could be deployed.

These two adaptive behaviours explain why our systems are termed Controlled Dynamic Distributed Information Fusion Systems (CDDIFS).

Fusion methods can be classified [Sasiadek (2002)] into three groups, according to their domain: probabilistic models such as Bayesian networks [Makarenko and Durrant-Whyte (2006)], approximation methods which

update a model of the environment and take decisions based on the predicted next state (for example Kalman filters [Shu-Li (2006)]) and interpolation methods such as fuzzy logic approaches [Bloch et al. (2003)] and neural networks [Parsons and Carpenter (2003)].

In our context, an *Information Fusion Process* (IFP) is defined as a discrete data-flow graph the nodes of which are fusion functions and the edges of which are links between function ports. Ports of a fusion node are connected to input, output and parameters of the fusion function. A fusion function f computes a tuple of output values $Y = (y_1, \dots, y_K)$ from a tuple of input values $X = (x_1, \dots, x_I)$, for a given vector $\theta = (\theta_1, \dots, \theta_J)$ of parameters:

$$(y_1, \dots, y_K) = f_{(\theta_1, \dots, \theta_J)}(x_1, \dots, x_I).$$

Distinction between input and parameter values comes from the fact that an input value is used for only one computation of the outputs, while a parameter is a sustained value, used for each computation, until it is modified. Our model is termed discrete since the tuples are discrete data and each function "consumes" one input tuple and produces one output tuple.

Our approach terms *Information Fusion System* (IFS) a hardware and software environment used to implement an IFP. It includes all the components needed to execute the fusion function implementations and to transfer information between the functions. The distributed aspect comes from the physical distribution of the run-time elements of the IFS: sensors, devices, computers, smart-phones, etc., are actually usually distributed. We call *execution framework* (EF) the computation environment where implementations of fusion nodes run (see section 3).

Our model deals with dynamicity in the sense that it copes with possible modifications of the IFS at runtime. Modifications may be the update of a fusion node implementation, the modification of network connections between the EFs or the failure of a part of the IFS. Note

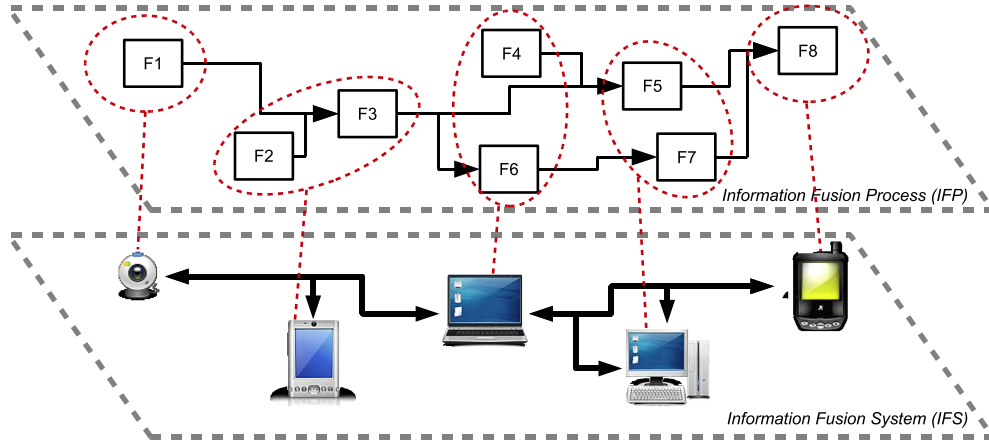

Fig. 1. Information Fusion Process (IFP) - Information Fusion System (IFS) relationship

that however in this paper, it is assumed that the IFP is fixed.

The paper is organised as follows. The next section explains how we control the IFS. Section 3 details our current implementation, while in section 4, we present the reconfiguration strategies we have designed and their implementation. An application example is detailed in section 5, and we indicate work in progress in section 6.

2. CONTROL OF DDIFS

Figure 1 presents the two levels view architecture of our proposal:

- the fusion graph, i.e. the fusion nodes (or fusion functions) and the connections between their input and output ports;
- the assignment of the fusion functions to the elements of the fusion run-time system.

The run-time DDIFS is controlled for what concerns error recovery and quality improvement.

Our system is developed in such a way that it checks for the IFS consistency i.e. the availability of the communication network between runtime sub-systems and the availability of these sub-systems. To this end, software sensors installed into the system provide both quantitative and qualitative measurements. The time interval between two executions of a fusion function or the amount of data present in some point of the system are such measurements. Thanks to these software sensors, errors and failures are detected and the system updates itself by changing its configuration in order to correct them.

The quality improvement is based on a Generalized Stochastic Petri Net (GSPN) [Marsan et al. (1998)] model of the configuration. We build a GSPN of the run-time system from which we derive a set of performance/dependability steady-state rewards $(r_n)_{1 \leq n \leq N}$. These rewards (CPU utilisation, response times, etc.) are computed from the Markov chain underlying the GSPN, with a tool, like GreatSPN [Chiola et al. (1995)] running on one of the host systems of the IFS. Details of the performance analysis of our system will be presented in a future paper. In short, we build a total order between configurations based on the rewards (r_n) .

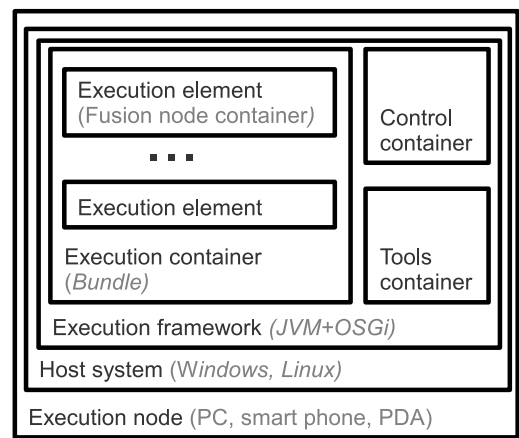

Fig. 2. Implementation details - Runtime frameworks hierarchy.

3. IMPLEMENTATION

To take into account modern architectures, our model distinguishes four hierarchical levels in an IFS (Figure 2). The lowest level is the physical machine level such as a Personal Computer, a smart-phone, etc. Each machine supports one or several host operating systems (as in virtualised systems). On top of a given host, an EF defines the fundamental architectural element of our IFS, assuming that every EF owns a unique (IP address, port number) pair. Each EF hosts the two sub-systems of our solution: an execution sub-system and a control sub-system.

The intend of our system is to take advantage of the skills of both information fusion experts and developers. Thus while the (information fusion) designer defines the data-flow graph that represents the fusion process through a graphical interface, developers may implement the execution codes of the fusion functions. In this way, the designer expresses specifications on the fusion process, and the developer only writes the selected fusion method Both do not take care about the deployment nor the modifications of the run-time system.

An implementation of the FP, also termed as a *configuration*, is defined by the choice of all the implementation elements translating the FP: fusion node implementations

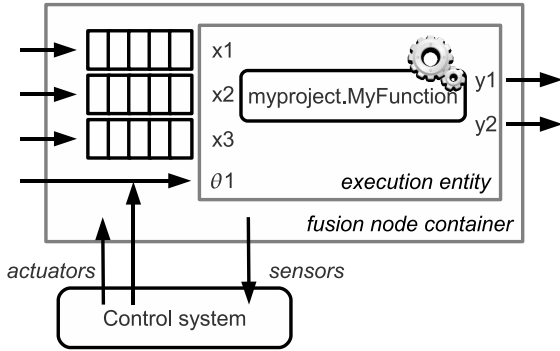

Fig. 3. Implementation details - Fusion node implementation.

(see below), assignment of the fusion nodes to EF (a fusion node is assigned to one EF), ports links mapping between fusion nodes. It assumes that EFs are linked through an undirected connected IP network (the *execution graph*) and that all the connections between fusion node ports are carried by this network (N). If the output y_k of a function f assigned to the EF e is the input x_i of f' assigned to e' , then the configuration defines the path between e and e' in N . This path may use intermediate EFs only used to connect the source and the destination EFs. As soon as a configuration is defined, it is deployed by the control sub-systems of the EFs.

An execution sub-system manages the execution elements corresponding to fusion nodes. In contrast, a control sub-system manages the execution sub-system: monitoring and analysis of the FP execution and reconfigurations of the IFS.

3.1 Fusion Node implementation

At the fusion process level, a fusion node consists of three sets of ports (inputs, parameters, outputs) and a mathematical description of the fusion function. Our model assumes that at least one implementation of each fusion function is available in the system and that all the implementations are valid i.e. they conform to their mathematical specification. To manage the execution of a fusion node related tasks, we introduce a fusion node container (Figure 3). It controls the implementation of the fusion function, termed the execution entity; it updates the value of the control parameters, and it transfers the software sensors values to the rest of the control system.

3.2 Execution mechanism

Implementation of the input port discrete semantics is based on queues storing discrete data, one queue being bound to each input port of a fusion node. Each computation of the fusion function un-queues one data item of each queue and uses the latched values of the parameters. Moreover, according to the *Best effort* policy defined in Section 4.3 the system tries not to lose data when unreachable fusion nodes are detected. Hence, the execution of the fusion function is started iff the following conditions are satisfied:

- no input queue is empty;

- the result of the computation may be sent to all its consumers.

The first condition is required to provide a value of each input port to the execution entity. The second condition is a design decision: we do not start a computation of the fusion function if we are not sure (to the best of our knowledge!) that the results could be processed by their receivers.

3.3 Implementation details

An implementation of our project is already deployed in order to experiment our results and was used to run a video conference smart-room[Wan et al. (2008)].

The current version of our system is deployed over OSGi [OSGi-Alliance (2005)] platforms [Rellermeyer et al. (2007)] linked by standard networks (LAN, Wi-Fi, Bluetooth). EFs are implemented as OSGi platforms and are linked together by R-OSGi services. The sub-systems are presently implemented as bundles, respectively for the control and the execution sub-systems, installed and started on each OSGi framework. Thanks to this structure the control sub-system can easily manage the execution sub-system especially during transitions.

The execution entities (code of the fusion nodes) defined by the configuration and the control elements are then registered as services in the OSGi framework and act together through services discovery and requests.

4. RECONFIGURATION OF DDIFS

The reconfiguration process, that is to say, the update of the implementation of the IFP on the IFS is made up of three phases:

- setting of the reconfiguration strategy,
- selecting a new configuration,
- deploying and starting the new configuration.

4.1 Reconfiguration setup

The reconfiguration of the system is twofold: correction of a configuration in order to restore the fusion process after an execution failure or an execution error, or improvement of the current configuration. The possible modification of a configuration relates to fusion function implementations, function assignments to EF or to input-output ports link mappings.

Configuration errors and failures The system is said to be in a failure state [Avizienis et al. (2004)] when one of its outputs cannot produce a result. Such a failure derives from an error. Our system tries to avoid as much as possible system failures, by detecting errors before they lead to failures. We detect two kinds of error:

- Inter-execution framework errors: an EF disappears or a communication channel is broken;
- Intra-execution framework errors: errors due to fusion node interactions (i.e. deadlock) and internal fusion node errors (for instance arithmetic overflow, timeout).

As mentioned in Section 2, software sensors, mostly throwing a Java exception, are used to detect these errors. Inter-execution framework errors are detected through monitoring of the communication links with programmed acknowledgments. Intra-execution framework errors throw Java exceptions caught by the control system of the execution framework.

Configuration improvement Even if there is no error, the control system tries to improve the runtime system permanently. To this end, firstly the control system periodically senses the model parameters from the execution system and computes the rewards associated to the model. If a significant variation is stated between two or more computations, the control system triggers a search for a new, and hopefully “better”, configuration. Secondly, the control system also launches a new configuration search when it detects a variation in the available runtime environment, for example due to a new available EF.

4.2 Selection of a new configuration

As soon as the need for a reconfiguration is launched, the system has to search for a new configuration. The search algorithm takes the description of the IFP and the constraints between the fusion nodes and the EFs as inputs. In fact, the selection of a new configuration due to reconfiguration involves the same steps as the initial configuration selection.

The search is based on a Constraint Programming approach already proposed by several researchers [Zhu et al. (2008); Anke et al. (2007)] in the context of the application component placement problem [Kichkaylo et al. (2003)]. The IFP provides a set of constraints such as the set of fusion nodes, the required links between output and input fusion nodes. The IFS constraints the possible configurations in several ways:

- each fusion function can be deployed on a subset only of the EF;
- connections between EF are fixed and given through an execution graph. We call “channel” a direct connection between two EF e and e' .
- for a given link l between y_k and x'_i , we must select a chain $((e_m, e_{m+1}))_{1 \leq m \leq M}$ of channels in the execution graph such that $e_1 = e$ and $e_{M+1} = e'$.
- a given EF must have enough memory resources to be able to run the fusion functions assigned to it.

Hence, for a given assignment of fusion nodes to EF together with the paths in the execution graph derived from links between fusion nodes, we are able to express automatically a set of constraints on these assignments.

There are in general several paths in the execution graph. For each path, we can define a “cost” based for instance on the number of its channels, i.e. its “length”, an effective usage cost, etc. We assume that all links from f to f' use the same path in the execution graph. Although we have designed our search in a generic cost way, in the present work we have implemented only the “length cost”. We then fix the “best” path as the shortest path (in the cost meaning) in the execution graph between the EF of the linked fusion nodes. These shortest paths between EF are

pre-computed for a given IFS with the Floyd-Roy-Warshall algorithm (see for instance [Cormen et al. (2001)]) and they are used by the Constraint Satisfaction Problem (CSP) solver. The CSP is now well defined and its variables are the assignments of fusion functions to the EF.

We can also add an optimisation criterium to the previous CSP to take into account the two antagonistic properties of a configuration:

- global maximal usage of the set of EFs: deploy the fusion nodes on as much as possible EF;
- global “short” physical communication between output and input fusion functions: deploy linked fusion functions on “neighbouring” EFs.

To do so, we define a generic cost function C of a configuration: $C = h(C_d, C_c)$ where C_d is a cost associated to the assignment of the fusion functions, and C_c is a cost associated to the mapping of the links to the channel chains and h a composition function. Note that C_d should be increasing with the “density” of the fusion functions on the EF. For instance, C_d could be:

$$C_d = \max_{e \in E} \{n(e)\} - \min_{e \in E} \{n(e)\}$$

with $n(e)$ being the number of fusion functions assigned to the node e and E the set of EFs. For C_c we can take a weighed (α_u) sum of the number of used channels:

$$C_c = \sum_{u \in U} \alpha_u n(u)$$

where $n(u)$ is the number of links (between fusion function ports) using the channel u and U is the set of channels of the execution graph. C_c should also be increasing with the “distribution” of the fusion functions in the IFS.

Finally, we send the problem to a CSP - with optimization-solver to get the configuration. We used the Choco solver which is available at <http://www.emn.fr/x-info/choco-solver/doku.php>. For the moment, the solver is run on one of several EF defined in a configuration file of the system.

Error recovery In the case of an error recovery, the control system selects as soon as possible a configuration compatible with the available resources. Hence, the search algorithm selects the first admissible configuration. Searching for a better configuration is performed during the next configuration improvement step.

Configuration improvement In this case, the control system searches for another “significantly better” configuration. To this end, from the current configuration, it derives a model of the configuration and computes its rewards as explained in Section 2. Then it throws a search for a new configuration as a CSP with an optimisation based on comparison of the rewards.

4.3 Transition between configurations

Independently from the reconfiguration strategy, the system applies the new configuration NC from the current configuration CC as follows. The system updates the location of the fusion node implementations, in case of new function assignments, and/or updates the execution

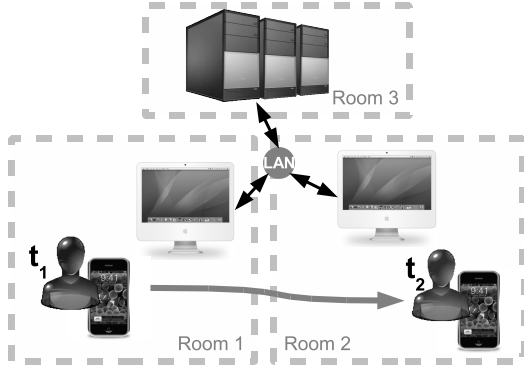

Fig. 4. Passer-by example of reconfiguration - architecture view.

entities, in case of implementation swaps. In both cases the system behaves according to a best effort policy.

Best effort The system tries to prevent loss of data-flow driven information present in it and already partially processed. To do so it is assumed that two different implementations of the same fusion function have the same semantics in the IFP. Thus, input data of a fusion node may come from computations ran in any configuration without invalidating the next produced results.

Let e' (in NC) be an updated version of the EF e (in CC). If e' can restore some data from the state of e , for instance by swapping an implementation of a fusion function, data waiting in the input queues are processed by the new execution entities. Hence there is no loss of data in this case.

On the contrary, partially processed data present on e are lost in case of assignments of the fusion functions of e to an EF different from e' . In such a reconfiguration, the links between the functions are mapped into new paths according to the new location of the fusion node containers. Each fusion node container, and therefore its data, is destroyed on e and instantiated on new EFs with empty input queues.

The current transition mechanism can be extended in order to cope special properties such as synchronization. In such a case and only when partially processed data are lost during the transition, some remaining data present in other EFs may be out of synchronization. To deal with this property, two extensions have to be added to our model: a label linked to the data that identifies the synchronization criterium, i.e. the time of sensors read, and a control element that deletes a data which is out of synchronization after a transition. Synchronization mechanism is presently not implemented in our system but is already defined in our model.

5. APPLICATION EXAMPLE

5.1 Passer-by example

In the passer-by example (Figures 4 and 5) the computers respectively located in room1 and room2 display two videos. The first one is the original view of the user's head (taken from a smart-phone). The second one is a filtered view of the original view, and the selected filter is chosen

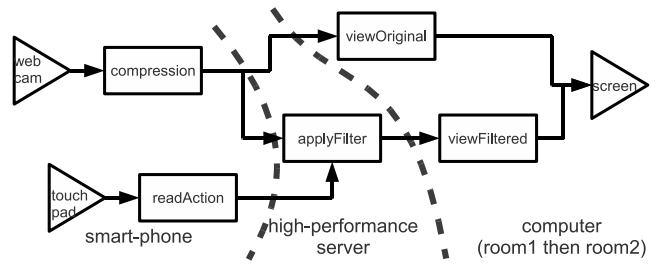

Fig. 5. Passer-by example of reconfiguration - process view.

by the user through a touch-pad. In the first configuration (t_1) the user is in the room1 and his smart-phone produces a video of his head. The video is processed by powerful computers located in room3 and the two videos are both displayed on the screen in room1. While the user is moving between the two rooms, the system detects that the connection with the smart-phone is lost and tries to reconfigure itself. As soon as the communication is restored with the smart-phone, the second configuration (t_2) executes the same fusion process but the last functions are assigned to the second computer in room2.

6. CONCLUSION

In this paper, we have presented problems raised by re-configuration features of a runtime model for controlled dynamic distributed information fusion system (CDDIFS). Dynamicity comes from the changing runtime support of our systems. Reconfiguring a CDDIFS system means either correcting it because of an error or a failure, or else increasing its quality of service. Our proposal is based on several functional components: - monitoring of the networked run-time system providing indication on the availability of the sub-systems and raw performance measures; - computation of a dependability model of the configurations running the Distributed Information Fusion System. - definition of a Constraint Satisfaction Problem (CSP) modeling the placement of the fusion functions onto the Execution Framework; We take advantage of efficient solvers for both computation of performance indices (rewards) based on the dependability model and resolution of the CSP. We are hence able to reconfigure in the “best way” with respect to a given set of criteria, our CDDIFS. Future work will deal first with full automation of all the components of our framework and installation of the system on top of other middleware systems like networked J2EE servers. We are also testing our framework with several kinds of Information Fusion Processes such as scientific computation systems, energy control systems, mechatronic systems.

REFERENCES

- Anke, J., Wolf, B., Hackenbroich, G., and Kabitzsch, K. (2007). A planning method for component placement in smart item environments using heuristic search. In S.B. Heidelberg (ed.), *7th IFIP WG 6.1 Int. Conf. Distributed Applications and Interoperable Systems (DAIS 2007)*, number 4531 in LNCS, 309–322. Paphos, Cyprus. doi:10.1007/978-3-540-72883-2_23.
- Avizienis, A., Laprie, J.C., Randell, B., and Landwehr, C. (2004). Basic concepts and taxonomy of dependable and

- secure computing. *IEEE Transactions on Dependable and Secure Computing*, 1, 11–33.
- Bloch, I., Géraud, T., and Maître, H. (2003). Representation and fusion of heterogeneous fuzzy information in the 3D space for model-based structural recognition - Application to 3D brain imaging. In *Fuzzy Set and Possibility Theory-Based Methods in Artificial Intelligence*, volume 148, 141–175.
- Chiola, G., Franceschinis, G., Gaeta, R., and Ribaud, M. (1995). GreatSPN 1.7: GRaphical Editor and Analyser for Timed and Stochastic Petri nets. *Performance Evaluation*, 24(1,2), 47–68.
- Cormen, T., Leiserson, C., Rivest, R., and Stein, C. (2001). *Introduction to Algorithms*. The Mit Press, Cambridge, MA, USA.
- Horré, W., Matthys, N., Michiels, S., Joosen, W., and Verbaeten, P. (2007). A survey of middleware for wireless sensor networks. Technical report, Department of Computer Science, K.U.Leuven, Katholieke Universiteit Leuven, B-3001 Heverlee (Belgium).
- Kam, M., Zhu, X., and Kalata, P. (1997). Sensor Fusion for Mobile Robot Navigation. In *Proceedings - IEEE*, volume 85, 108–119. IEEE Institute of electrical and electronics.
- Kichkaylo, T., Ivan, A., and Karamcheti, V. (2003). Constrained component deployment in wide area networks using ai planning techniques. In *Proc. of the 17th IEEE Int. Parallel and Distributed Programming Symposium (IPDPS 2003)*.
- Maître, H. and Bloch, I. (1997). Image Fusion. In *Information Fusion to Data Mining*, volume 41, 329–335.
- Makarenko, A. and Durrant-Whyte, H. (2006). Decentralized Bayesian algorithms for active sensor networks. *Information Fusion*, 7(4), 418–433.
- Marsan, M.A., Bobbio, A., and Donatelli, S. (1998). *Petri nets in performance analysis: an introduction*, 211–256. In Reisig and Rozenberg (1998).
- OSGi-Alliance (2005). OSGi service platform - release 4: <http://www.osgi.org>.
- Parsons, O. and Carpenter, G.A. (2003). ARTMAP neural networks for information fusion and data mining: map production and target recognition methodologies. *Neural networks*, 16, 1075–1089.
- Reisig, W. and Rozenberg, G. (eds.) (1998). *Lectures on Petri Nets I: Basic models*. Number 1491 in LNCS. Springer-Verlag. Advances in Petri nets.
- Rellermeyer, J.S., Alonso, G., and Roscoe, T. (2007). R-OSGi: Distributed applications through software modularization. In *Proc. of the ACM/IFIP/USENIX 8th Int. Middleware Conf. (Middleware 2007)*, number 4834 in LNCS. Springer.
- Sasiadek, J.Z. (2002). Sensor fusion. *Annual Reviews in Control*, 26(2), 203–228.
- Shu-Li, S. (2006). Multi-sensor optimal fusion fixed-interval Kalman smoothers. *Information Fusion*.
- Wan, K., Todo, A., Sawada, H., Passalacqua, O., Benoit, É., Huguet, M.P., and Moreaux, P. (2008). Video conference smart room: an information fusion system based on distributed sensors. In *Proceedings of Mecatronics2008*.
- Zhu, X., Santos, C., Beyer, D., Ward, J., and Singhal, S. (2008). Automated application component placement in data centers using mathematical programming. *Int. J. Netw. Manag.*, 18(6), 467–483.